

In-Tank Pump DW300m (9-305)



This 340lph DW300m is the only 300+ LPH pump with drop-in fitment for the Ford Mustang GT, and the GT500 dual pump module. To achieve Ford-specific fitment, we engineered this pump to replicate the OE's unique compact size, end cap geometries, electrical connector, and outlet barb. The result is a 340LPH pump that precisely installs into Ford modules with no wire splicing, no hacking, and no zip-ties. A single DW300m will support over 500hp on any 2v/3v mustang. In addition the DW300m is compatible with pulse with modulated pump drivers and is fully compatible with ethanol blended fuels. All DW fuel pumps are backed by a 3-year no fault warranty.

Specifications

Weight	10.6oz (300g)
External Materials	Electroplated Steel
Inlet Fitting	7.7mm ID, 11.0mm OD
Outlet Fitting	5/16" Hose Clamp
PRV Activation	100 psi
Impeller Design	Single Scroll Composite Turbine
Connector Terminal	Spade Pos/Neg
Min Voltage Input	6 Volts
Max Voltage Input	18 Volts
Current Draw 40psi	11.2 Amps (13.5v)

Delivery Characteristics

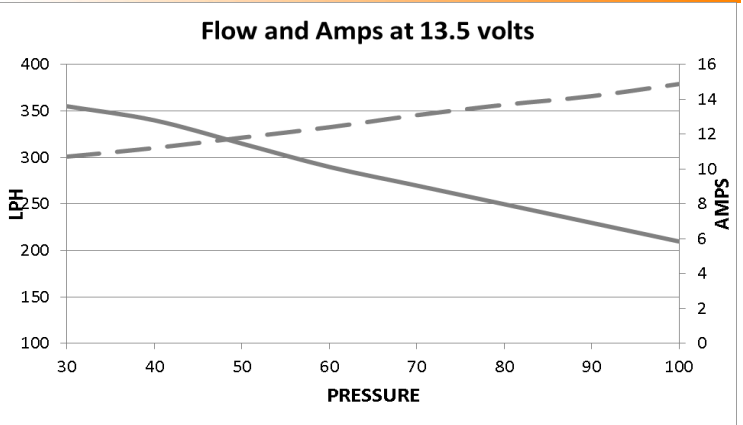

PSIG	30	40	50	60	70	80	90	100
AMP	10.7	11.2	11.8	12.4	13.1	13.7	14.2	14.9
LPH	355	340	315	290	270	250	230	210

Dimensions

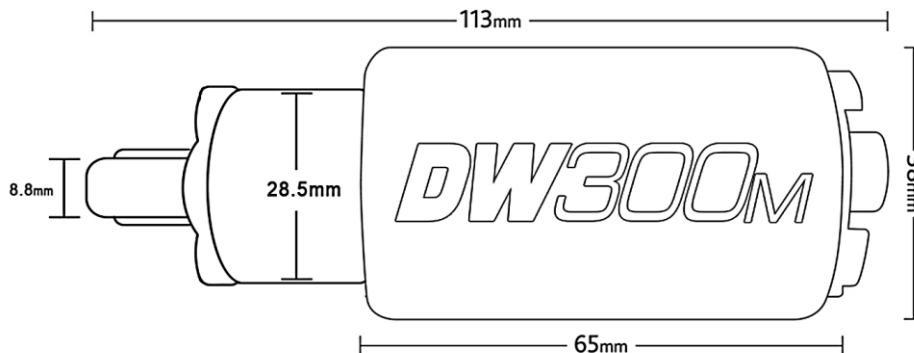

THIS PRODUCT MAY BE USED SOLELY ON VEHICLES USED IN SANCTIONED COMPETITION WHICH MAY NEVER BE USED UPON A PUBLIC ROAD OR HIGHWAY, UNLESS PERMITTED BY SPECIFIC REGULATORY EXEMPTION